

HIGH PRECISION X AXIS POSITIONING TABLE - LINEAR BALL SCREW SLIDES

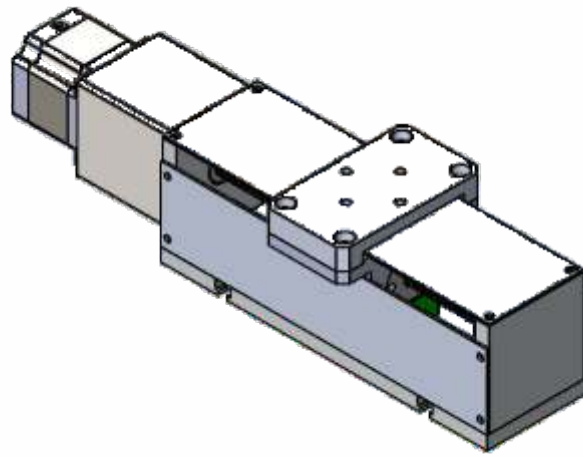

X SLIDE WITH SHEET METAL COVER

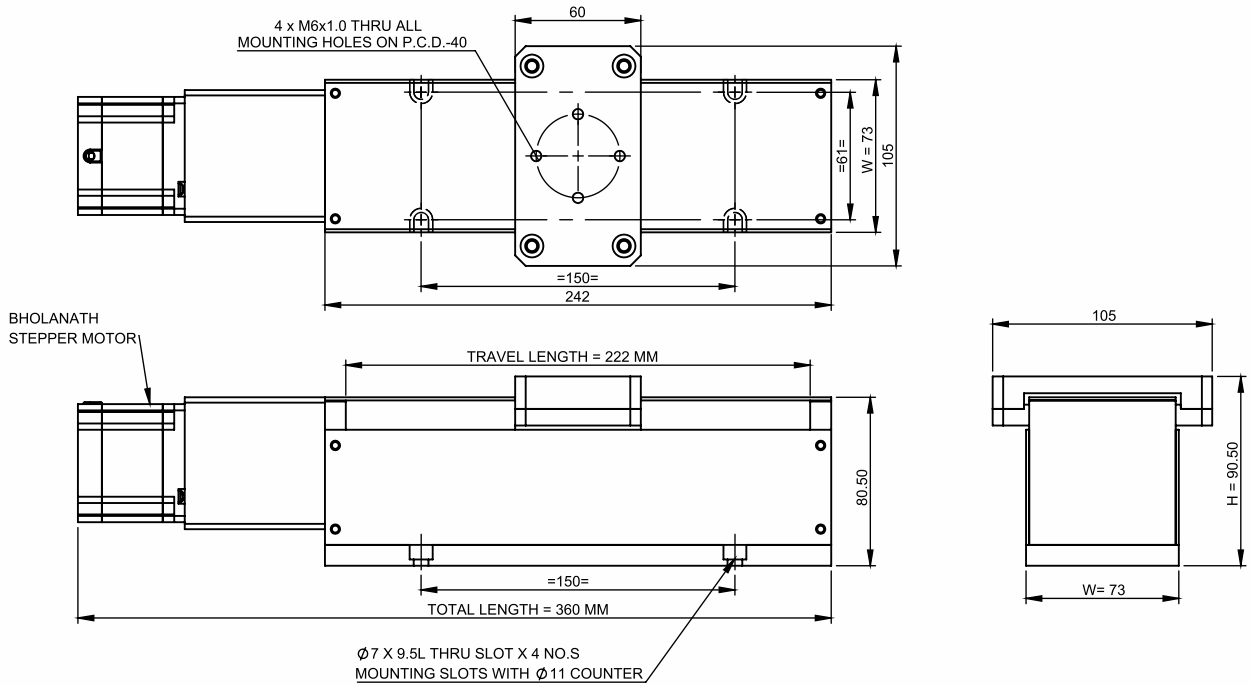
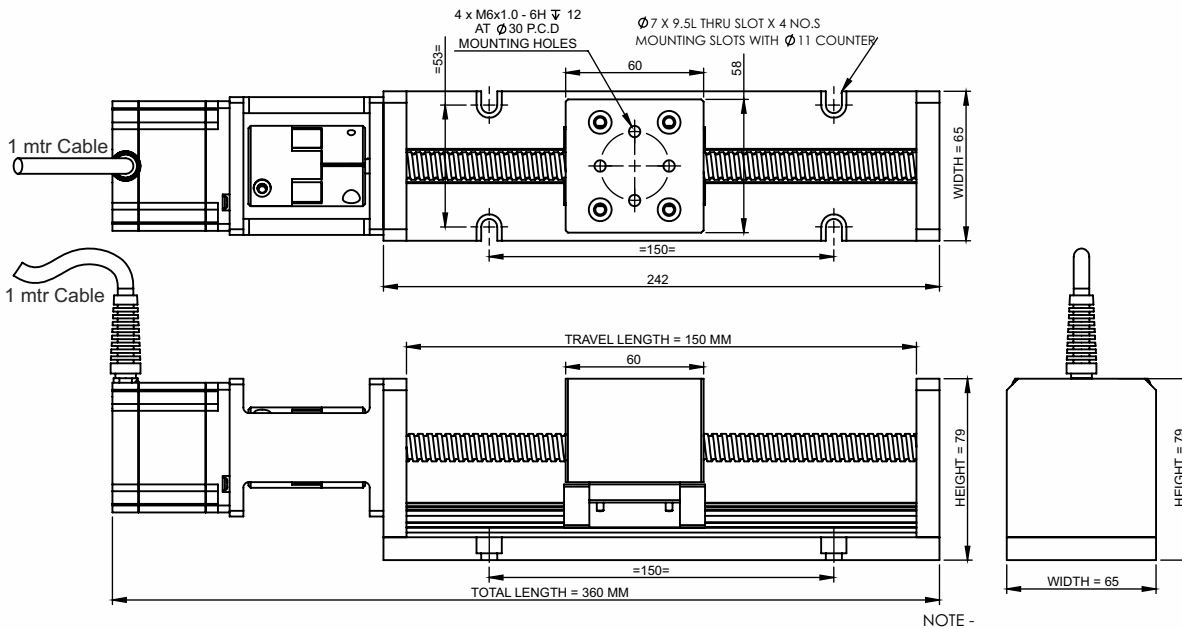

Regular slide without bellow cover

TECHNICAL DATA

SPECIFICATION Model no		BHBS-XSLIDE-150-M
1	Maximum load carrying capacity(kg)	63
2	Permissible Feed Speed	0 to 75 mm/sec
3	Positioning Accuracy (mm)	≤ 0.02
4	Degree Of protection	IP 40
5	Total Weight of slide (KG)	3.5

Note:- The Load Calculation is Based On Horizontal Movement. For Vertical Movement Kindly Consider Safety Factor Of 0.6 And Motor With Brake.

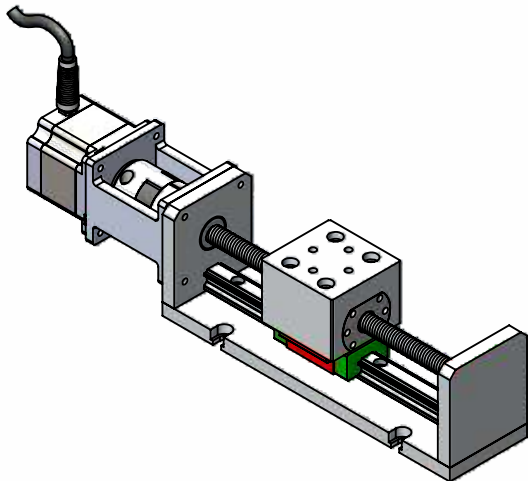
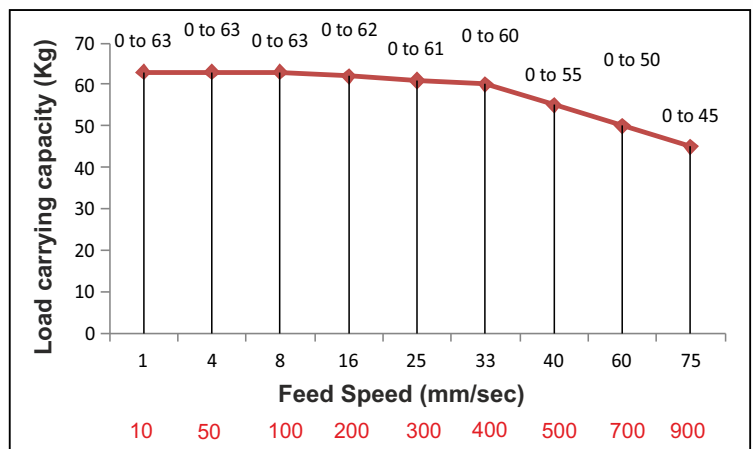

Bholanath Precision Engineering Pvt.Ltd.

1002 Opposite Old Passport Office, Wagle Estate, MIDC, Thane West - 400604.India.
Tel Nos - 91 - 22 - 69181700 (100 Lines) / 9821671733
Mobile No : 9920903825/9821671733/9930514603/9819515543/9323166582.
Email Id - support@bholanath.in/ nisha.k@bholanath.in
Website - www.bholanath.in